

(download unter <http://www.horter.de/doku/>)

Stückliste:

Bauteil	Bezeichnung	Anz.
R1	Widerstand 270 Ω (rt li bn)	1
R2	Widerstand 10 kΩ (bn sw or)	1
R3	Widerstand 470 kΩ (ge li ge)	1
R4	Widerstand 4,7 kΩ (ge li rt)	1
V1	LED 3mm 20mA	1
C1-C2	Keramik-Kondensator 100 nF	2
C3	Trimmkondensator 4 - 40pF	1
C4	Keramik-Kondensator 27 pF	1
C5	Keramik-Kondensator 10 nF	1
C6	Elektrolyt-Kondensator 10 yF	1
IC1	PCF8583P + Fassung 8pol	1
IC2	NE555 + Fassung 8pol	1
Q1	Uhrenquarz 32,768 MHz	1
JP1, JP2	Pfostenleiste 3 pol. + Jumper	2
ST1, ST2	Anschlussklemme 6pol.	2

Bestückungsplan

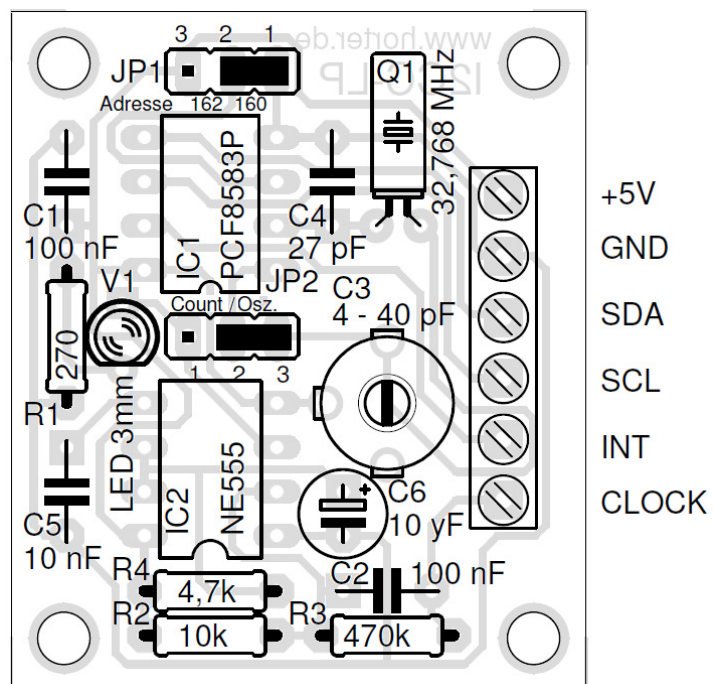

Info:



langer Fuß
ist Pluspol