

I²C-Switch 4 Kanal (4 channel)

Zur Montage auf DIN-Schienen (Hutschienen) geeignet

I2HSS V2

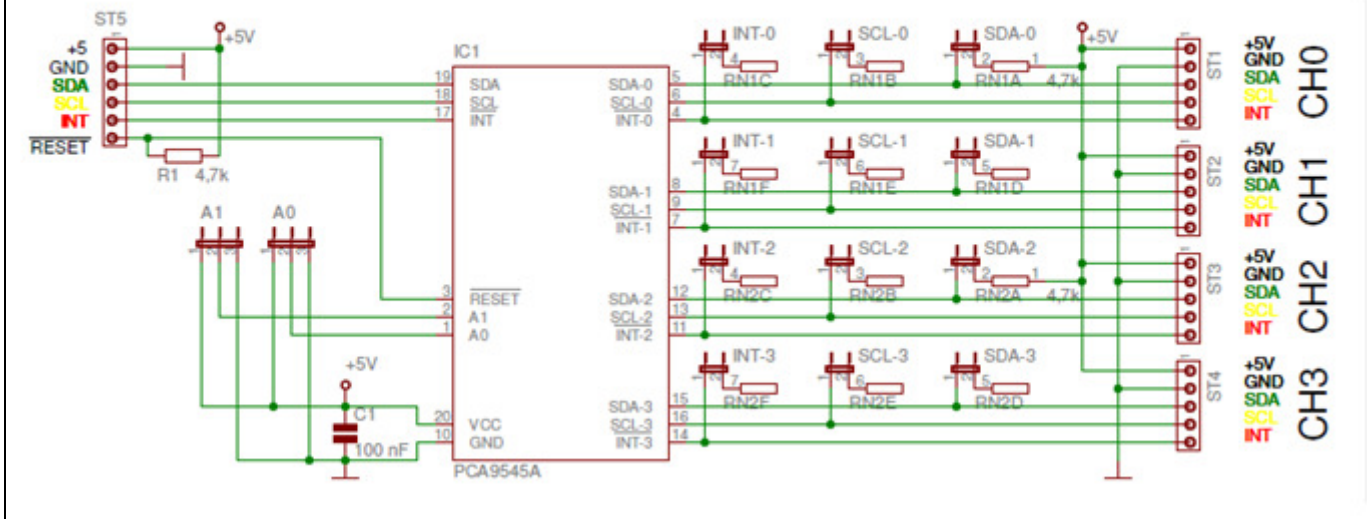

(download unter <http://www.horter.de/doku/>)

Adressen:

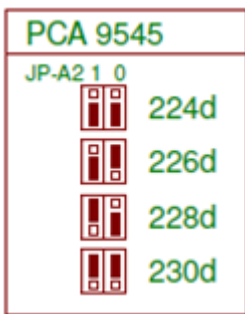

Stückliste:

Bauteil	Bezeichnung	Anz.
RN1, RN2	Widerstandsnetzwerk 6x 4,7k	2
R1	Widerstand 4,7 k (ge li rt)	1
C1	Keramik-Kondensator 100 nF	1
IC1	PCA 9545A SMD SO-20	1
JP1-15	Pfostenleiste 30 pol. Jumper	14
ST1-4	Anschlussklemme 5 pol.	4
ST5	Anschlussklemme 6 pol.	1

Info:



Markierung beachten!



Bestückungsplan

